

MRL DS00002

MARAL 3 AXLES 34m³ TIPPER SEMI TRAILER

TRANSPORTATION COMFORT



TECHNICAL DESCRIPTIONS:

MARAL

3 AXLES 34m³ TIPPER SEMI TRAILER

MARAL TRAILER
SINCE 1989

- **Chassis Construction:** Chassis and other metal pieces are made of high - strength steel (S500MC) with special automatic Co2 argon welding machine.

- **Cylinder:** Five-stage telescopic jack stand (170-190 EMB), EU Standard with related accessories

- **Body Construction:** Walls: thickness is 4 mm and reinforced by special steel diagonal bars (S500MC). Floor: thickness is 5 mm and reinforced by special steel cross beams (S500MC).

- **Braking System:** EBS System (Electrical Anti Block Brake System) with RSP (Roll Stability Program) Disc and Drum, Knorr® / Wabco® (germany) Two double acting diaphragm brake chamber per axle.



TECHNICAL DESCRIPTIONS:

- **Suspension and axles:** 3x9 ton EU standard disc brake or drum brake, front lift axle
- **Painting:** Shot blasted, according to SA2/5 and washed by special material, painted with a layer of epoxy primer and of polyurethane final coat
- **Electric System:** 7 and 15 Pole quick release connector, Austrian Pair of 24 volts rear light, side light and alarming system from Aspock with LED Type.
- **Axle/ Suspension:** axle with air bags cylinder air suspension system with special shock absorber Lower and Rise Capability of Trailer
- **Landing Legs:** Static Capacity 50 Tons & Dynamic Capacity 24 Tons (JOST) Germany
- **King pin:** 2 Inch JOST king pin made in Germany
- **Tires:** 6 pieces 385/65R22.5
- **Rim:** 6 pieces rims 22.5 x 11.75 tubless
- **Accessories:**
 - Automatic front lift axle
 - Plastic Chock
 - Holder for fire extinguisher
 - 60 Lit Water tank
 - Rear 3- step sliding ladder
 - Front galvanized ladder
 - Plastic chock
 - Trailer park lock system
 - Fix rear bumper
 - Toolbox
 - Galvanized spare Tires holder
 - 6 pcs mud guards and 2 mud flaps
- **Options:**
 - Holding standard and certificate of welding inspection and dimensional control and hydraulic test
 - Optional Spare Tires and rim
 - Side gearbox shaft to be installed by company



TECHNICAL SPECIFICATIONS:

| | | | |
|---------------|------------------------------|--|---------|
| King pin load | 11500 kg | Centre of rear axle to rear edge of body | 1490 mm |
| Axle load | 27000 kg | Outside width | 2550 mm |
| Tare weight | 8000 kg | Overall height | 3100mm |
| Pay load | 33000 kg | Overall length | 10800mm |
| 5th wheel | 1150 - 1200 mm | Body volume | 32m3 |
| Truck type | Designed for 6 wheels Trucks | Body access height | 1550mm |
| Axle spread | 1310 mm | Body access width | 2375mm |
| Wheelbase | 6450 mm | Body access length | 9125mm |
| Rear overhang | 2800mm | Max. tipping angle | 42° |

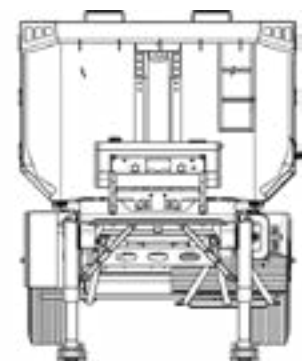
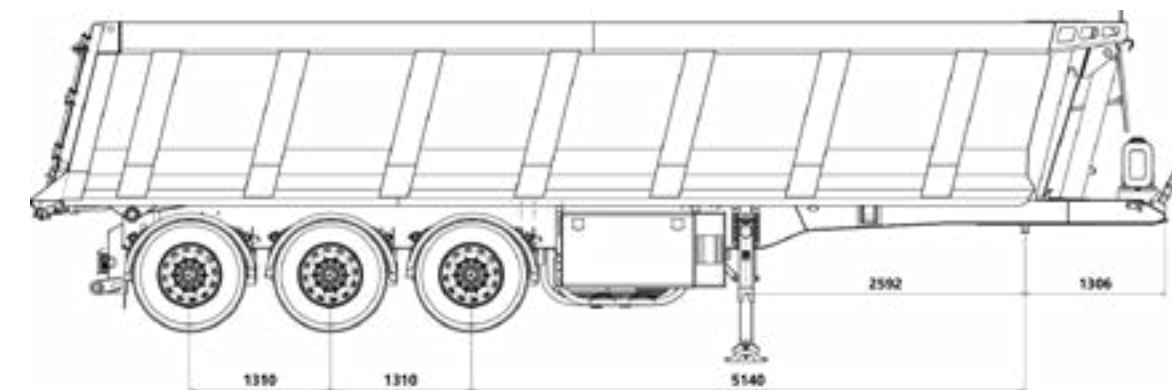

MARAL

3 AXLES 24m³ TIPPER
SEMI TRAILER

MARAL TRAILER
SINCE 1989

- **Chassis Construction:** Chassis and other metal pieces are made of high - strength steel (S500MC) with special automatic Co2 argon welding machine.

- **Cylinder:** Five-stage telescopic jack stand (170-190 EMB), EU Standard with related accessories

- **Body Construction:** Walls: thickness is 6 mm and reinforced by special steel diagonal bars (S500MC)
Floor: thickness is 8 mm and reinforced by special steel cross beams (S500MC)

- **Braking System:** EBS System (Electrical Anti Block Brake System) with RSP (Roll Stability Program) Disc and Drum, Knorr® / Wabco® (germany) Two double acting diaphragm brake chamber per axle.



TECHNICAL DESCRIPTIONS:

- **Suspension and axles:** 3x9 ton EU standard disc brake or drum brake, front lift axle

- **Painting:** Shot blasted, according to SA2/5 and washed by special material, painted with a layer of epoxy primer and of polyurethane final coat

- **Electric System:** 7 and 15 Pole quick release connector, Austrian Pair of 24 volts rear light, side light and alarming system from Aspöck with LED Type.

- **Axle/ Suspension:** axle with air bags cylinder air suspension system with special shock absorber Lower and Rise Capability of Trailer

- **Landing Legs:** Static Capacity 50 Tons & Dynamic Capacity 24 Tons (JOST) Germany

- **King pin:** 2 Inch JOST king pin made in Germany

- **Tires:** 6 pieces 385/65R22.5

- **Rim:** 6 pieces rims 22.5 x 11.75 tubless

- **Accessories:**

- Automatic front lift axle
- Plastic Chock
- Holder for fire extinguisher
- 60 Lit Water tank
- Rear 3- step sliding ladder
- Front galvanized ladder
- Plastic chock
- Trailer park lock system
- Moveable rear bumper
- Toolbox
- Spare Tires holder
- 6 pcs mud guards and 2 mud flaps

- **Options:**

- Holding standard and certificate of welding inspection and dimensional control and hydraulic test
- Optional Spare Tires and rim
- Side gearbox shaft to be installed by company



TECHNICAL SPECIFICATIONS:

| | | | |
|---------------|------------------------------|--|---------|
| King pin load | 11500 kg | Centre of rear axle to rear edge of body | 1445 mm |
| Axle load | 27000 kg | Outside width | 2550 mm |
| Tare weight | 7900 kg | Overall height | 3100mm |
| Pay load | 33000 kg | Overall length | 9050 mm |
| 5th wheel | 1150 - 1200 mm | Body volume | 24m³ |
| Truck type | Designed for 6 wheels Trucks | Body access height | 1550mm |
| Axle spread | 1310 mm | Body access width | 2325mm |
| Wheelbase | 5000 mm | Body access length | 7320mm |
| Rear overhang | 2755 mm | Max. tipping angle | 42° |

